

Piazza

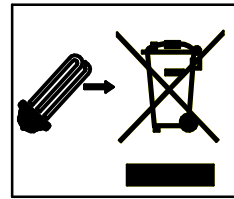

- PL Wyłączyć zasilanie przed wymianą lampy.
- EN Disconnect the unit before changing the lamp.
- F Debrancher l'appareil avant de changer la lampe.
- D Von den Auswechseln der lampe die Leuchte von der Netzspannung trennen.

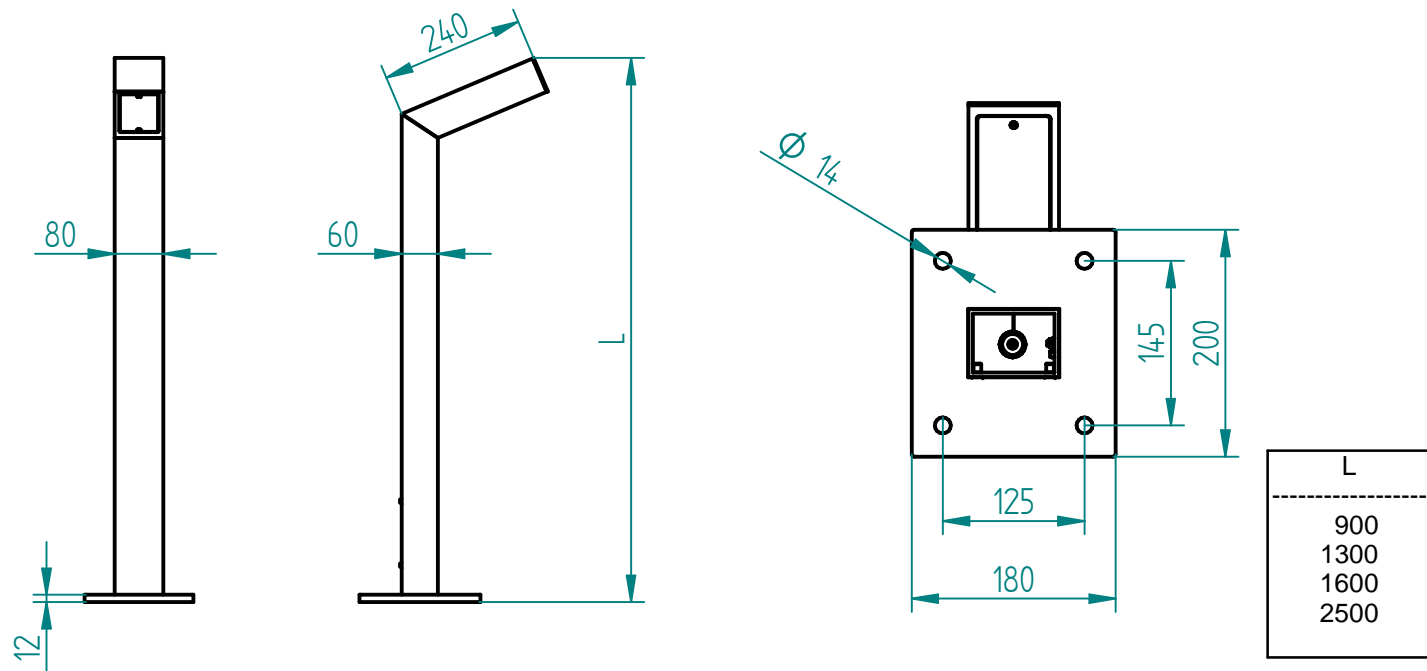

1

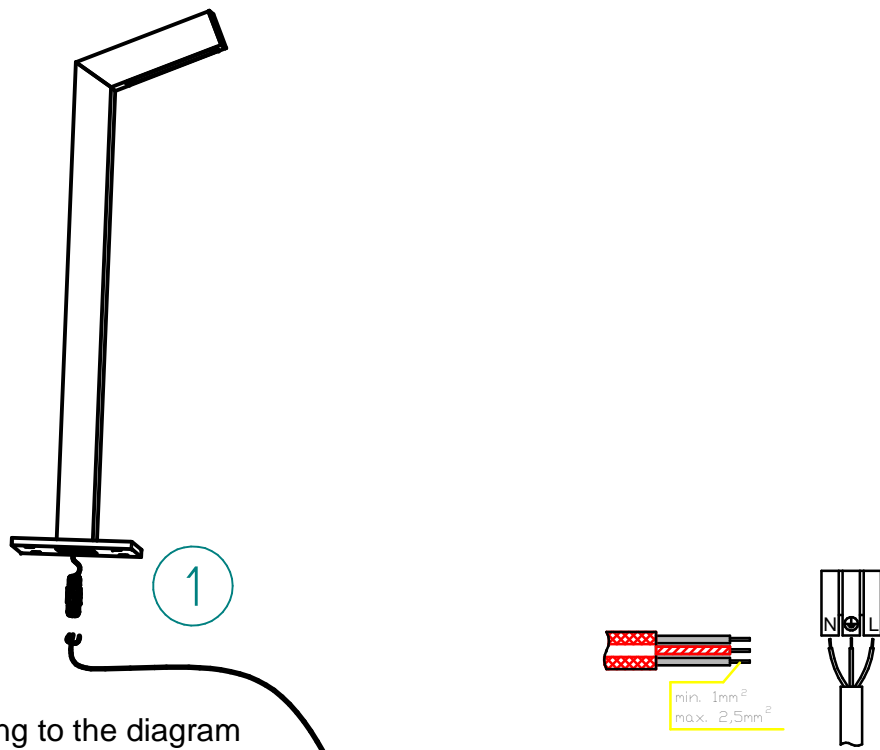

1 - Connect power cable according to the diagram

KEYLIGHT

2

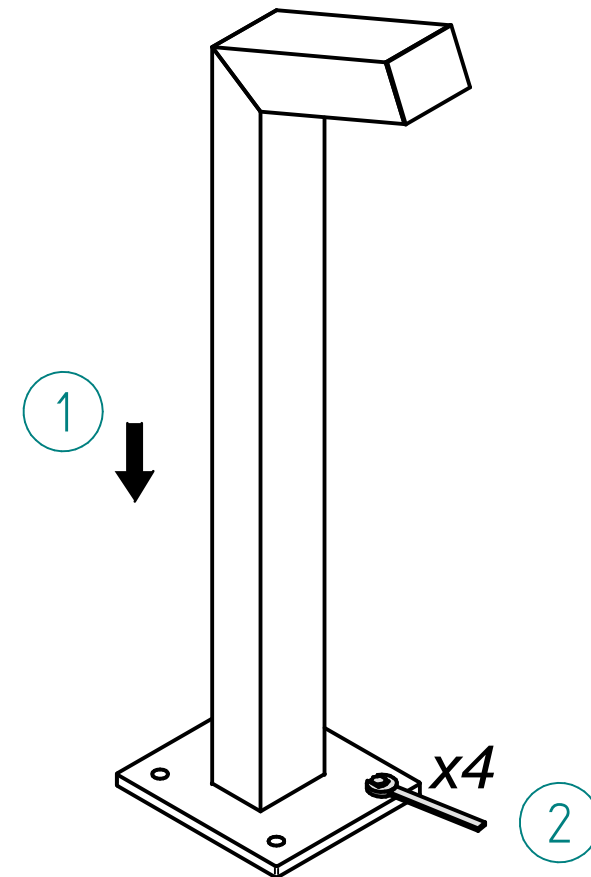

- 1 - Put the luminaire on the mounting base
- 2 - Fix the luminaire to the base

3

