

Pile 1m

Instrukcja montażu
 Installation instructions
 Instructions de montage
 Montageanleitung
 ИНСТРУКЦИЯ МОНТАЖА

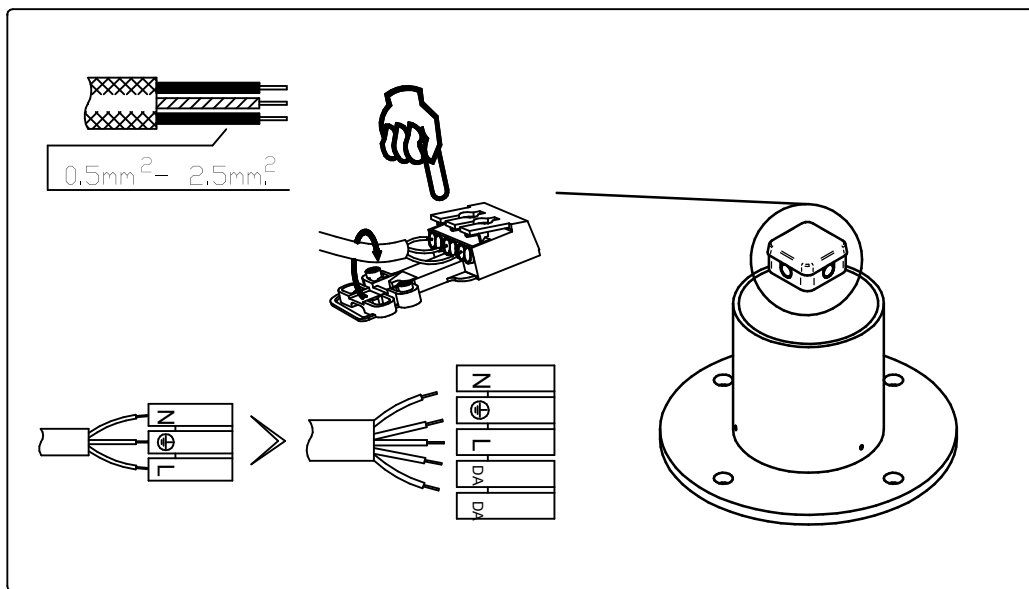

- PL - Wyłączyć zasilanie przed wymianą lampy.
- UK - Disconnect the unit before changing the lamp.
- F - Debrancher l'appareil avant de changer la lampe.
- D - Von den Auswechseln der lampe die Leuchte von der Netzspannung trennen.

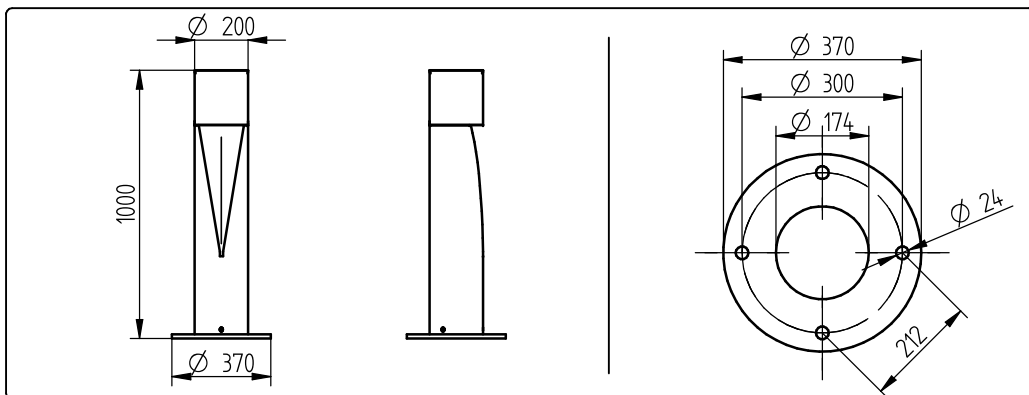

- PL - Temp. przechowywania/otoczenia i wilgotność względna.
- UK - Storage temp./ambient temp. and humidity.
- F - Température de stockage, temp. ambiante et humidité.
- D - Temp. Lagerung / temp. relative Luftfeuchtigkeit.

-20°C...+80°C
 -20°C...+40°C
 10... 90%

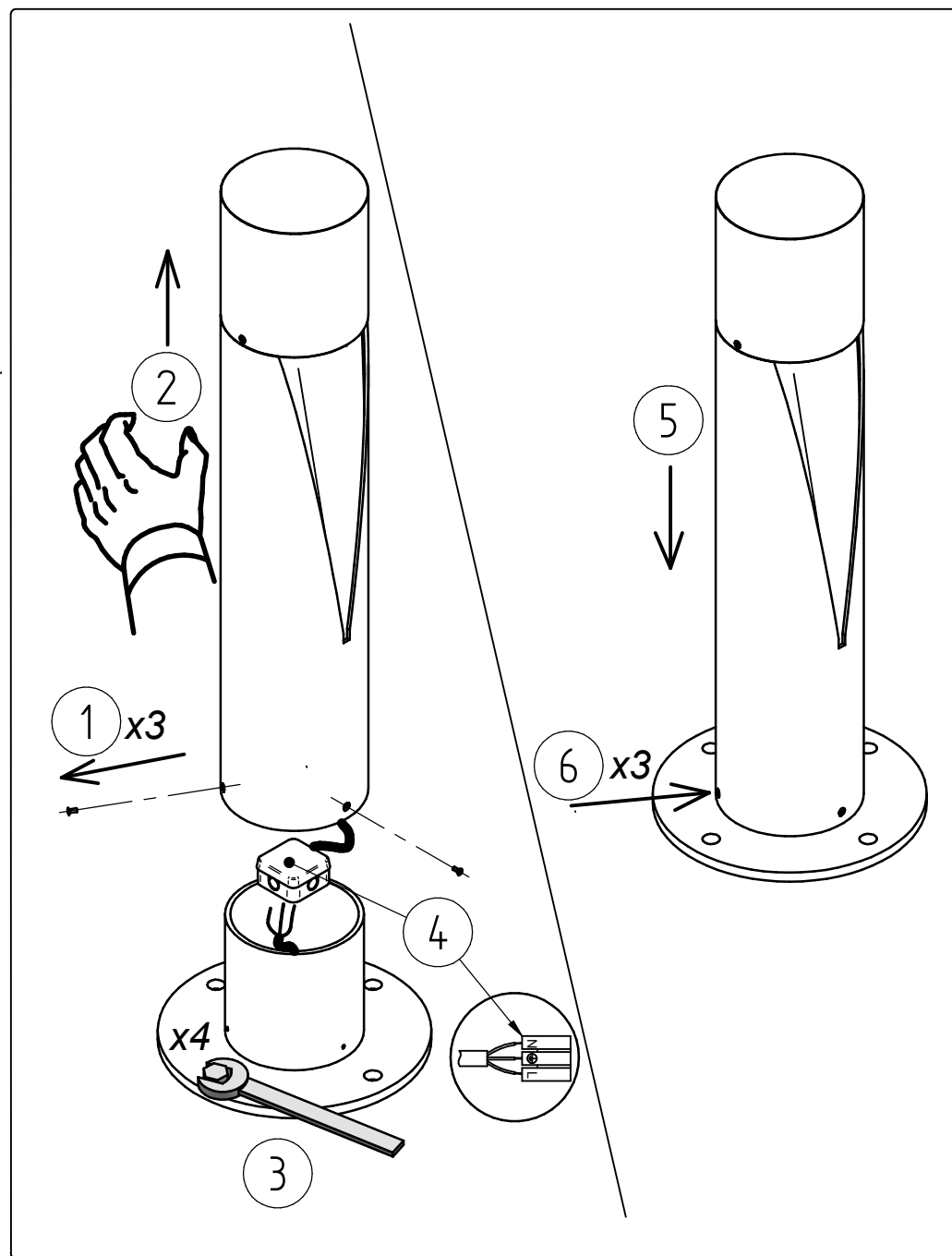

KEYLIGHT